

A mechanical model of the human throat for swallowing rheology

Mats Stading^{1,2}, Johanna Andersson¹ and Fredrik Holmberg³

¹RISE Research Institutes of Sweden, Bioeconomy and Health, Gothenburg, Sweden

²Chalmers University of Technology, Industry and Materials Science, Gothenburg, Sweden

³Animato, Domsjö, Sweden

ABSTRACT

Swallowing disorders, or dysphagia, is a growing problem especially as the population gets older. In the age group above 70, 40 % suffer due to factors such as degenerative diseases and side effects of medication. These persons must drink thickened beverages and eat texture adjusted foods. The product development of thickeners and texture-adjusted foods require confirmation of the effect on swallowing. This can be done in a mechanical model of the throat before involving dysphagia patients. A previous research model, the “Gothenburg Throat” has been modified for product development and its function verified by thickened water.

INTRODUCTION

The human throat is a complex, active channel transporting both food and air to our internal organs. The upper part, the pharynx, is critical for correct swallowing that rely on coordination between breathing and food transport. A multitude of disorders may occur which are collectively referred to as dysphagia. There is a strong correlation between dysphagia and age, and it affects 10-30% of all people aged 65 and above ¹. In Sweden, the fraction of the population older than 65 is 20% and in Japan, it is approaching an outstanding 30%, as compared to the global average which is less than 10%. Life expectancy is also expected to increase globally.

Dysphagia often leads to insufficient food intake, sarcopenia and frailty. Age-related dysphagia is rarely curable and requires a supply of texture-modified foods and beverages that are possible to swallow without any difficulty ². For beverages this means thickening a Newtonian low-viscosity fluid to a shear-thinning fluid with higher viscosity. The increased viscosity slows down flow and gives the aged body time to do all actions necessary for safe swallowing such as stop breathing, closing the windpipe and letting the epiglottis cover the entrance to the windpipe. It is beneficial if the thickening also induces fluid elasticity which promotes fluid cohesivity and thereby safe swallowing³⁻⁵. Solid foods for dysphagia management, i.e. texture-modified foods, are designed to be smooth, moist and without particles to produce a bolus which can be swallowed safely ⁶.

The rheological properties of the thickened beverage or texture-modified food bolus strongly influence the flow through the pharynx ^{5,7,8}. The flow is crucial for safe and pleasant swallowing, especially for those suffering from dysphagia. The flow can be assessed clinically by X-ray video-fluoroscopy or manometry which are elaborate, cumbersome studies especially for someone suffering from dysphagia and *in vitro* techniques are therefore preferred ².

Mackley et al. and Noh et al. have previously simulated the swallowing process has been *in vitro* ^{9,10}. The Mackley model

was named “The Cambridge throat” and simulates the swallowing tract by a square channel and fixed, open epiglottis. The flow is observed by high-speed video of a bolus squeezed into the channel mimicking the tongue thrust movement. Despite the simplicity the Cambridge throat presents a good starting point for in vitro simulation of swallowing process. The in vitro model presented by Noh et al. used video-fluoroscopy to follow the bolus flow. Both models conclude that a thickened bolus travels slower through the pharynx and too viscous boluses leave post-swallow residues negative for swallowing. All existing in-vitro, mechanical models have been reviewed by Qazi and Stading¹¹.

A more advanced model named “The Gothenburg Throat” has previously been presented and evaluated^{4, 7, 8, 12}. The model simulates pharyngeal swallowing while allowing monitoring of the bolus velocity profile and shape, as well as the pressure at three locations. The oral phase is modelled using a syringe delivering a bolus of fixed volume and speed into the pharynx. The device is based on the human pharyngeal geometry with specifications taken from the literature. The elliptical flow channel is rigid, mimicking the geometry at the instance when the bolus passes through the pharynx. The device can simulate closing of the windpipe by employing a valve and a moving epiglottis. The upper esophageal sphincter (UES) is modelled using a clamping valve, and a separate valve opens and closes the channel to the nasopharynx.

The velocity profile, movement and location of the bolus are monitored with a moving ultrasonic transducer^{4, 13}. The position and movement of the ultrasonic transducer and the opening of the valves and the epiglottis are controlled from a connected PC, which also collects the pressure and velocity data. This means that the relative timing of the separate events can be controlled, thus mimicking the various states of dysphagia.

The aim of the present paper is to introduce a simplified version of the Gothenburg Throat aimed at practical application in e.g. product development.

THEORY

The initial speed of the bolus can be calculated as follows. The bolus is injected in the pharynx model using a tipping cup driven by a weight via a line pulley. The speed is therefore determined by the mass of the bolus and the weight without the involvement of other mechanical or electronic systems. This provides a simple speed setting with good repeatability and a relatively good imitation of the human mouth. However, the ratio of speed to weight is not linear and must be calculated for each bolus weight. The rotating parts including a bolus consisting of 30 cm³ liquid with a density of 1 g/cm³ are showed together with the entire mechanical system including the weight in Fig. 1. The mass, centre of gravity and moment of inertia of the rotating parts, including the liquid, have been calculated using SolidWorks CAD and calculation software. This resulted in a mass of $m_r = 0.244$ kg, a moment of inertia with the rotation axis as reference point $I_r = 534 \times 10^{-6}$ kgm² and a movement of the centre of gravity $\Delta h_r = 42.2$ mm calculated between the starting position and the emptying position.

The speed is most easily calculated via the energy principle where, at the moment of emptying, the kinetic energy equals the decrease in positional energy. The distance from the centre of the cup opening to the centre of the rotation axis is $r_1 = 53$ mm while the distance from the axis of rotation to the line the weight is attached to is $r_w = 53/2 = 26.5$ mm. The liquid will thus have a speed twice the speed of the weight. The angle between the horizontal plane and the impact surface is 125°, resulting in that the weight will be lowered $\Delta h_w = -57.8$ mm while raising the centre of gravity of the rotating parts $\Delta h_r = 42.2$ mm. Assuming that the losses in the axis bearings are negligible

$$\Delta E_p + \Delta E_k = 0 \quad (1)$$

where ΔE_p is the change in potential energy while ΔE_k is the change in kinetic energy. The change in potential energy is

$$\Delta E_p = m_w g \Delta h_w + m_r g \Delta h_r \quad (2)$$

where m_w is the mass of the weight, g the acceleration of gravity, Δh_w is the position change of the weight, m_r is the mass of the rotating parts and Δh_r is the position change of the center of gravity of the rotating parts. The change in kinetic energy is

$$\Delta E_k = I_r \omega^2 / 2 + m_w v_w^2 / 2 \quad (3)$$

where I_r is the moment of inertia of the rotating parts, ω is the angular velocity at the impact and v_w is the velocity of the weight at the impact. $v_w = \omega r_w$ modify Eq. 3 to

$$\Delta E_k = I_r \omega^2 / 2 + m_w v_w^2 / 2 = I_r \omega^2 / 2 + m_w r_w^2 \omega^2 / 2$$

Eq. 2 and Eq. 3 in Eq. 1 gives

$$\Delta E_p + \Delta E_k = m_w g \Delta h_w + m_r g \Delta h_r + I_r \omega^2 / 2 + m_w r_w^2 \omega^2 / 2 = 0$$

Eq. 1 is then

$$\omega = \left(\frac{-m_w g \Delta h_w - m_r g \Delta h_r}{I_r / 2 + m_w r_w^2 / 2} \right)^{1/2}$$

$$v_l = r_l \omega \quad (4)$$

Eq. 1 in Eq. 4 gives

$$v_l = r_l \omega = r_l \left(\frac{-m_w g \Delta h_w - m_r g \Delta h_r}{I_r / 2 + m_w r_w^2 / 2} \right)^{1/2}$$

Inserting numerical values from the model:

$m_r = 0.244 \text{ kg}$	$I_r = 534 \times 10^{-6} \text{ kgm}^2$
$\Delta h_r = 42.2 \text{ mm}$	$\Delta h_w = -57.8 \text{ mm}$
$r_l = 53 \text{ mm}$	$r_w = 26.5 \text{ mm}$

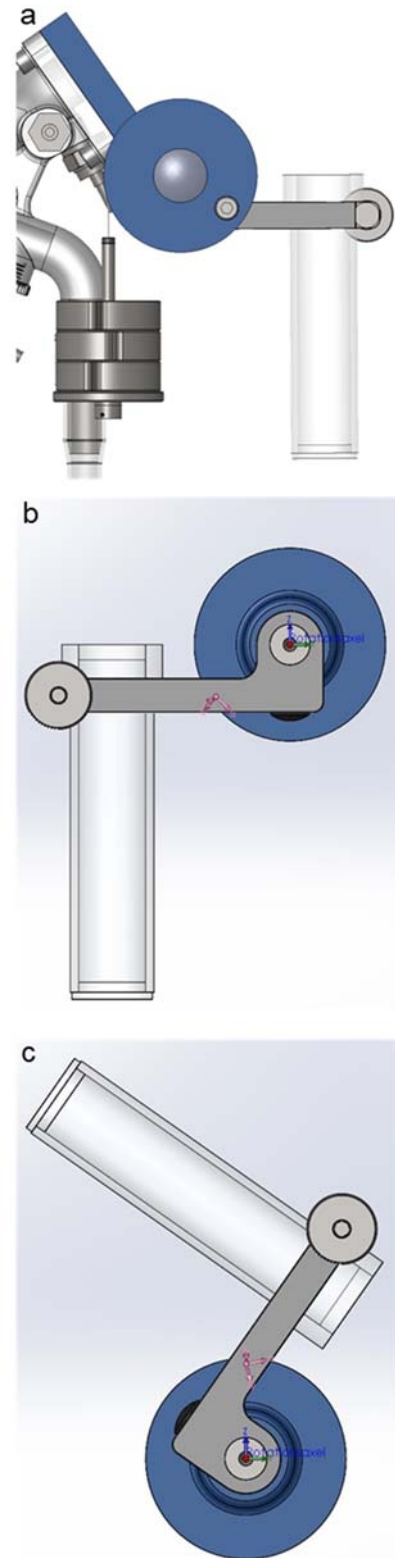

Figure 1. a) The entire mechanical assembly, b) the cup in start position and c) the cup in position of impact where the liquid leave the cup.

Gives the initial fluid velocity v_1 from the mass used m_w in Table 1.

Table 1. Velocity v_1 from the mass m_w used

m_w [kg]	v_1 [m/s]
0.20	0.32
0.30	0.72
0.40	0.93
0.50	1.08
0.60	1.19
0.70	1.34
0.80	1.34
0.90	1.40
1.00	1.46

MATERIALS AND METHODS

The fluids studied were water and a thickened water, both at 20°C. The thickened water was thickened using Thick & Easy (Hormel Health Labs, MN, USA) to a concentration of 4% w/w which corresponds to “nectar-like” in the NDD scale¹⁴. A food colorant was added for visualisation purposes.

RESULTS AND DISCUSSION

Model design

The simplified version of the Gothenburg Throat is shown in Fig. 2. It is designed around the pharynx channel connected to a mechanism for injecting the bolus and a continuation of the channel to the esophagus. The pharynx has an exit to the windpipe, the trachea, and a moveable epiglottis which can cover the opening. The trachea has a valve mimicking the action of the vocal cords that close the trachea for 1-2 s while swallowing. All actions are controlled from a PC in the control unit. The model has a camera mount with a dial for the rotation angle and a gauge and dial for the pressure in the trachea, as well as two pressure sensors along the channel. All control mechanisms and electronics are housed in a splash-proof, stainless steel casing. The design follows the

previous Gothenburg Throat model with some modifications¹².

Pharynx channel: The pharynx has the same geometry as the previous model but with thinner walls to accommodate transducer and camera access from all sides¹². The pharynx can easily be opened along a diagonal cross section by loosening ten screws. This allows visualizing the flow from both side and front views and the lid can be removed for cleaning.

Injection of the bolus: The piston of the previous model is replaced by a tipping cup driven by a pulley and weights providing the momentum. By choosing the weight relative to the bolus volume, a pre-set bolus speed can be attained. The motion is started from the control software displayed on the touch screen.

Bolus visualization: The model has an arm for mounting a camera or a velocity sensor. The angle of the arm is monitored by a digital dial at the top of the mount. A camera can monitor the bolus flow by high-speed video, or an ultrasonic transducer can be used similarly to the previous model for the velocity profile^{4, 12, 13}.

Larynx pressure: The pressure in the airways can be set by a dial and gauge on the control unit to simulate aspiration by premature breathing during swallowing. Breathing should be halted until the bolus has passed over the epiglottis, but if the apnea is too short a negative pressure in the larynx may cause aspiration.

Assessment of aspiration: A small cup at the entrance to the airways can be unscrewed after a swallowing to gravimetrically measure the amount of fluid aspirated into the airways.

Software: All settings are performed on a touch screen on the front of the control unit.

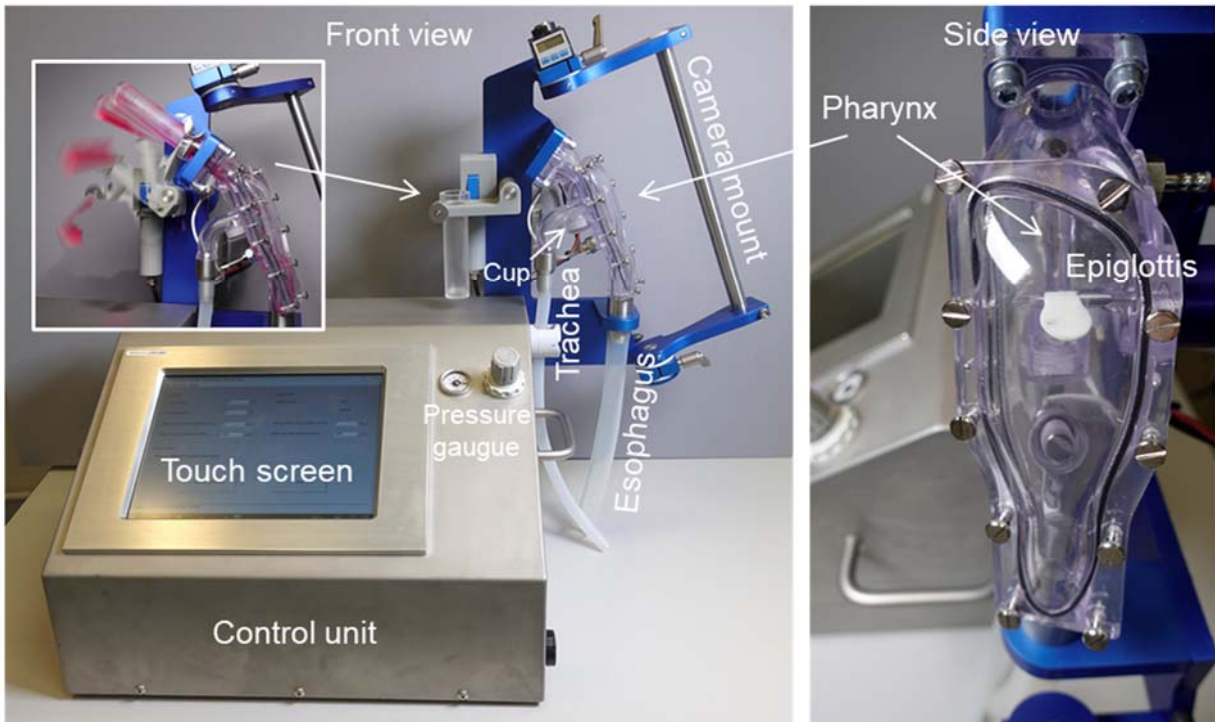

Figure 2. The industrial version of the Gothenburg Throat model. The inset shows the action of the cup delivering the bolus into the pharynx.

The timing of all actions can be controlled: bolus injection, epiglottis movement, closing and opening of the larynx valve, and end of the experiment. There are fixed settings for healthy swallowing and various degrees and forms of dysphagia.

Validation and results

A comparison of swallowing of water and thickened water was used as a validation of the model. For dysphagia patients thickening of water is performed to achieve slower flow and to avoid aspiration¹⁵. The rheological properties of the thickened water are shown in Fig 3. As expected, the thickened water is shear thinning and the mechanical spectrum shows that it behaves as an entangled polymer solution with $G' \approx G''$. Thickened fluids for dysphagia management are commonly characterized by the shear viscosity at 50 s^{-1} which for this fluid is 100 mPa s . This corresponds to “nectar-like” on the NDD scale and “2. Mildly thick” on the IDDSI scale^{14, 16}.

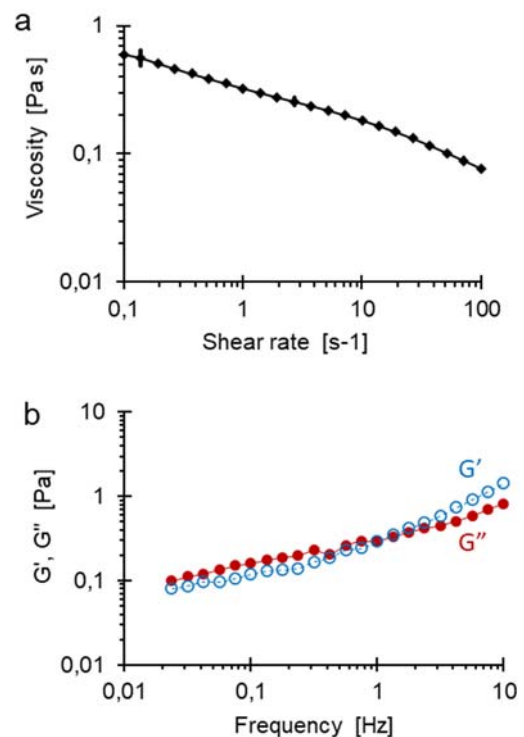

Figure 3. Thickened water with 4% (w/w) Thick & Easy at 20°C, a) viscosity curve, and b) mechanical spectrum.

The flow through the pharynx channel of the throat model was monitored by high-speed video and snapshots are shown in Fig. 4. The model was set to simulate severe swallowing disorders where the epiglottis does not close and the patient breathes in during swallowing. The latter was simulated by a negative pressure in the larynx.

The low viscosity of water causes turbulent flow through the pharynx as shown in the top pictures in Fig. 4. The thickened water, on the other hand, flows laminarily on the sides of the open epiglottis. The effect of the thickening was also captured by the amount of fluid in the small cup after the larynx entrance. For a 15 ml bolus of water 0.65 g water was captured in the cup with the epiglottis open, whereas for the thickened water no fluid entered the larynx.

The velocity of the container cup was measured from high-speed video. For 0.5 kg weight on the pulley the final speed was measured to 1.2 m/s which can be compared to the calculated speed of 1.08 in Table 1. Within measurement accuracy an added bolus of up to 20 ml did not influence the speed as the momentum is small compared to that from the 0.5 kg weight.

CONCLUSION

A simplified version of the Gothenburg Throat was developed aimed at product development of thickened fluids and texture-modified foods. The model is robust and easy to use and regulated through a touch screen interface.

Swallowing of water and thickened water in the model simulate swallowing disorders showed aspiration of the water but as *in vivo* not for the thickened water.

ACKNOWLEDGEMENTS

The Swedish Research Council Formas is gratefully acknowledged for funding this research.

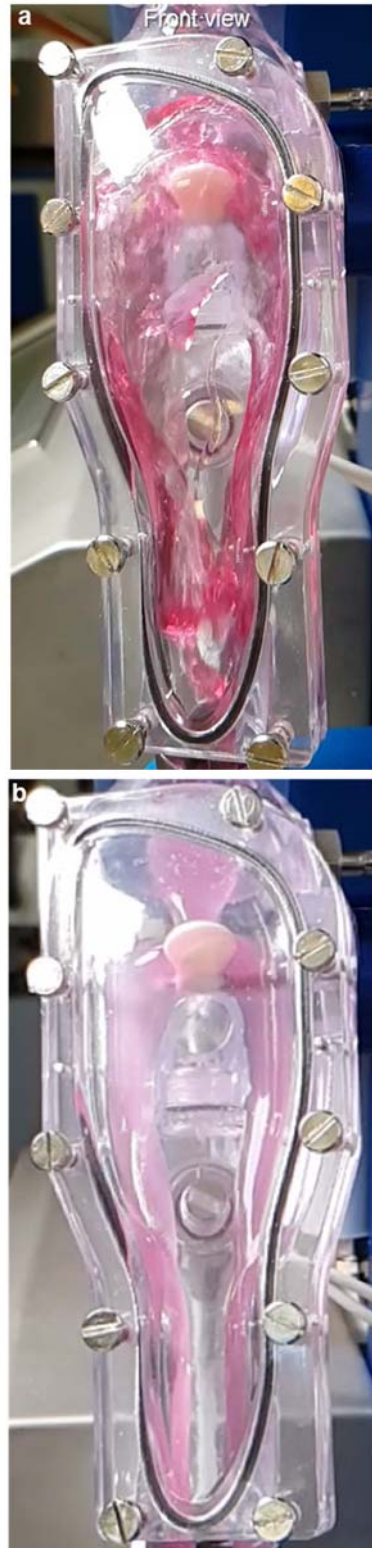

Figure 4. Snapshot from flow through the swallowing model of a) water, and b) thickened water passing around the open epiglottis.

REFERENCES

1. Barczy SR, Sullivan PA, Robbins JA. How Should Dysphagia Care of Older Adults Differ? Establishing Optimal Practice Patterns. *Semin Speech Lang.* // 31.12.2000 2000;21(04):0347-0364. doi:10.1055/s-2000-8387
2. Ekberg O. *Dysphagia - Diagnosis and Treatment*. 2 ed. Diagnostic Imaging. Springer International Publishing; 2019:924.
3. Wendin K, Ekman S, Bülow M, et al. Objective and quantitative definitions of modified food textures based on sensory and rheological methodology. *Food and Nutrition Research*. 06/28 2010;54doi:10.3402/fnr.v54i0.5134
4. Qazi WM, Ekberg O, Wiklund J, Kotze R, Stading M. Assessment of the Food-Swallowing Process Using Bolus Visualisation and Manometry Simultaneously in a Device that Models Human Swallowing. *Dysphagia*. 2019/12/01 2019;34(6):821-833. doi:10.1007/s00455-019-09995-8
5. Nystrom M, Qazi WM, Bülow M, Ekberg O, Stading M. Effects of rheological factors on perceived ease of swallowing. *Applied Rheology*. 2015;25(6):40-48.
6. Stading M. Bolus rheology of texture-modified food – effect of degree of modification. *J Text Stud*. 2021;doi:10.1111/JTXS.12598
7. Waqas MQ, Wiklund J, Altskär A, Ekberg O, Stading M. Shear and extensional rheology of commercial thickeners used for dysphagia management. *Journal of Texture Studies*. 2017;48(6):507-517. doi:10.1111/jtxs.12264
8. Qazi WM, Ekberg O, Wiklund J, Mansoor R, Stading M. Simultaneous X-ray Video-Fluoroscopy and Pulsed Ultrasound Velocimetry Analyses of the Pharyngeal Phase of Swallowing of Boluses with Different Rheological Properties. *Dysphagia*. 2020/02/11 2020;doi:10.1007/s00455-020-10092-4
9. Mackley MR, Tock C, Anthony R, Butler SA, Chapman G, Vadhilo DC. The rheology and processing behavior of starch and gum-based dysphagia thickeners. *Journal of Rheology*. 2013;57(6):1533-1553. doi:10.1122/1.4820494
10. Noh Y, Segawa M, Sato K, et al. Development of a robot which can simulate swallowing of food boluses with various properties for the study of rehabilitation of swallowing disorders. presented at: International Conference on Robotics and Automation; 2011;
11. Qazi WM, Stading M. In vitro models for simulating swallowing. In: Ekberg O, ed. *Dysphagia - Diagnosis and Treatment*. 2 ed. Springer International Publishing; 2019:924.
12. Stading M, Waqas MQ, Holmberg F, Wiklund J, Kotze R, Ekberg O. A Device that Models Human Swallowing. *Dysphagia*. 2019/10/01 2019;34(5):615-626. doi:10.1007/s00455-018-09969-2
13. Wiklund J, Shahram I, Stading M. Methodology for in-line rheology by ultrasound Doppler velocity profiling and pressure difference techniques. 10.1016/j.ces.2007.05.007. *Chemical Engineering Science*. 2007;62(16):4277-4293.
14. National Dysphagia Diet Task Force ADA. *National Dysphagia Diet: Standardization for Optimal Care*. American Dietetic Association; 2002.
15. Newman R, Vilardell N, Clavé P, Speyer R. Effect of Bolus Viscosity on the Safety and Efficacy of Swallowing and the Kinematics of the Swallow Response in Patients with Oropharyngeal Dysphagia: White Paper by the European Society for Swallowing Disorders (ESSD). journal article. *Dysphagia*. 2016;31(2):232-249. doi:10.1007/s00455-016-9696-8
16. International Dysphagia Diet Standardisation Initiative I. Accessed September 22, 2020. <https://iddsi.org/>